

H · Y · T · E · K

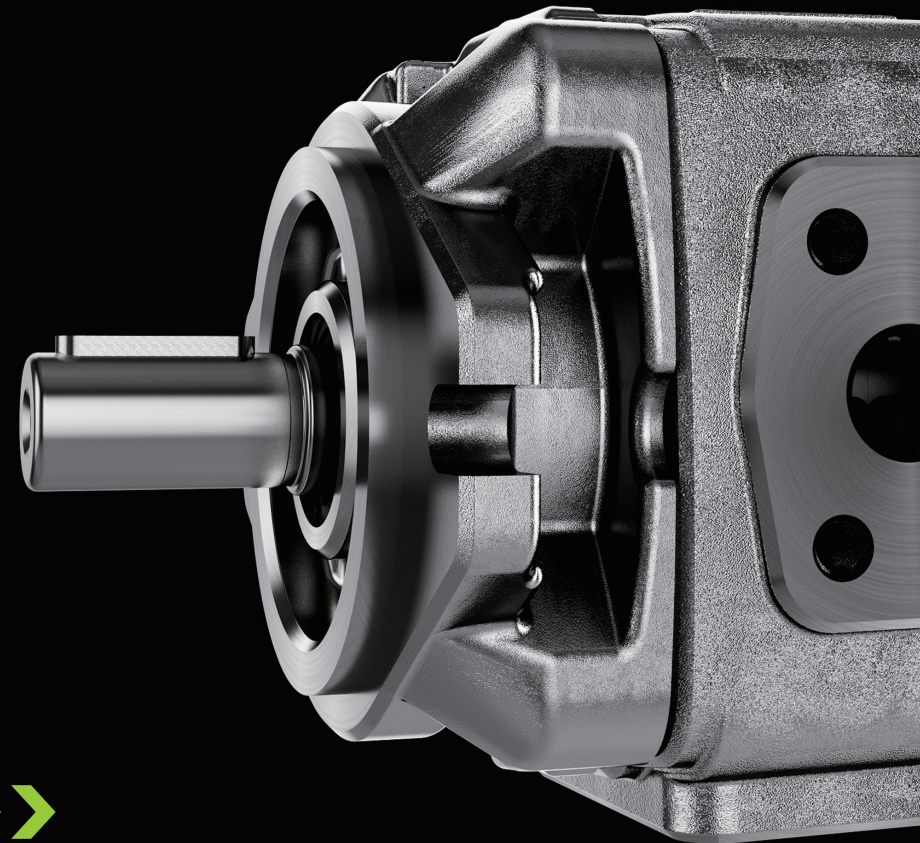

**HYTEK**

# **INTERNAL GEAR PUMP**



## HG SERIES GEAR PUMP

### HG SINGLE PUMP

Product show and brief introduction

HG0 Size: 8 20

HG1 Size: 25 63

HG2 Size: 80 160



#### Content:

Model code	.1
Specification	2
Installation dimensions	.4
Port flange dimensions	.9

## MODEL CODE

	HG	1	-40	-01	R	-V	P	C	
<b>PUMP</b>									
Internal gear pump	HG								
<b>CODE</b>									
Displacement 8 20	0								
Displacement 25 63	1								
Displacement 80 160	2								
<b>SIZE</b>									
Displacement (cc/rev)									
8	10	13	16	20	25	32	40	50	63
80	100	125	160						
<b>CODE</b>									
	01								
<b>DIRECTION OF ROTATING (VIEWED ON SHAFT END)</b>									
CW	R								
<b>SEAL TYPE</b>									
Viton	V								
<b>SHAFT</b>									
Key shaft	P								
Splined shaft	S								
<b>MOUNTING FLANGE</b>									
SAE 2 holes	C								

## SPECIFICATION: STRUCTURE

HG is fixed displacement and intermittent compensation internal gear pump. Front body (1), Middle housing (2), Rear Cover (3), Shaft bearing (4), Annular gear (5), Sliding bearing (6), Slide plate (7), Locating rod (8), Crescent side plate (9), Crescent main plate (19) and Plastic rod (11).

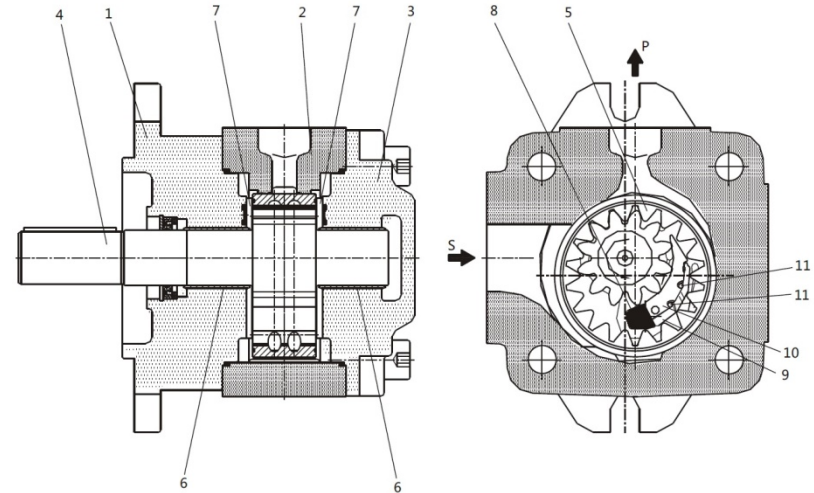

MODEL	SIZE	DISP. cc/rev	PRESSURE bar		ROTATING SPEED r/min		WEIGHT kg
			Rated	Max	Max	Min	
<b>HG0</b>	8	8.0	250	300	3000	600	4.4
	10	10.0	315	350	3000	600	4.6
	13	13.3	315	350	3000	600	4.9
	16	16.0	315	350	3000	600	5.2
	20	20.0	315	350	3000	600	5.6
<b>HG1</b>	25	25.3	315	350	3000	200	14.5
	32	32.7	315	350	3000	200	15
	40	40.1	315	350	3000	200	16
	50	50.7	315	350	3000	200	17
	63	63.7	315	350	3000	200	18.5
<b>HG2</b>	80	81.4	315	350	3000	200	43.5
	100	100.2	315	350	3000	200	45.5
	125	125.3	315	350	3000	200	48
	160	162.8	210	260	3000	200	52

## INSTALLATION

HGO-※-01R-VPC (P SHAFT)

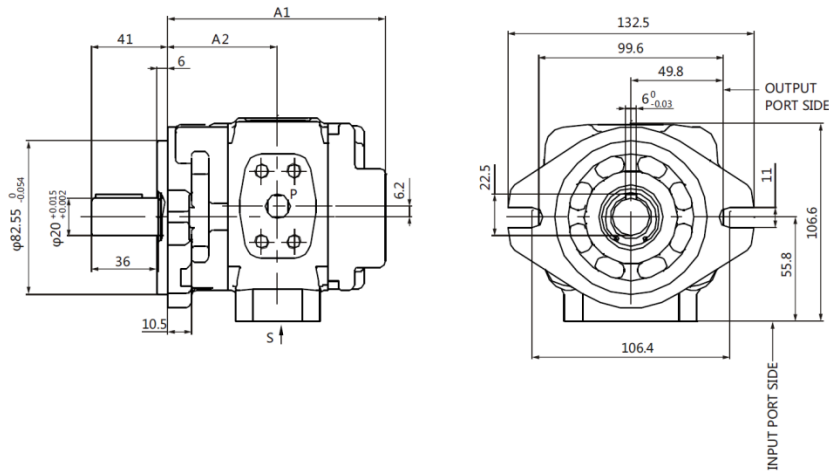

MODEL CODE	A1	A2	S	P
<b>HGO-08-01R-VPC</b>	107	54	SAE 3000 ¾ (Ø19)	SAE 3000 ½ (Ø13)
<b>HGO-10-01R-VPC</b>	111	56	SAE 3000 1 (Ø21)	
<b>HGO-13-01R-VPC</b>	117.5	59.25		
<b>HGO-16-01R-VPC</b>	123	62	SAE 3000 1¼ (Ø26)	SAE 3000 ¾ (Ø18)
<b>HGO-20-01R-VPC</b>	131	66		

Port flange dimension page 9

## INSTALLATION DIMENSIONS

HGO-※-01R-VSC (S SHAFT)

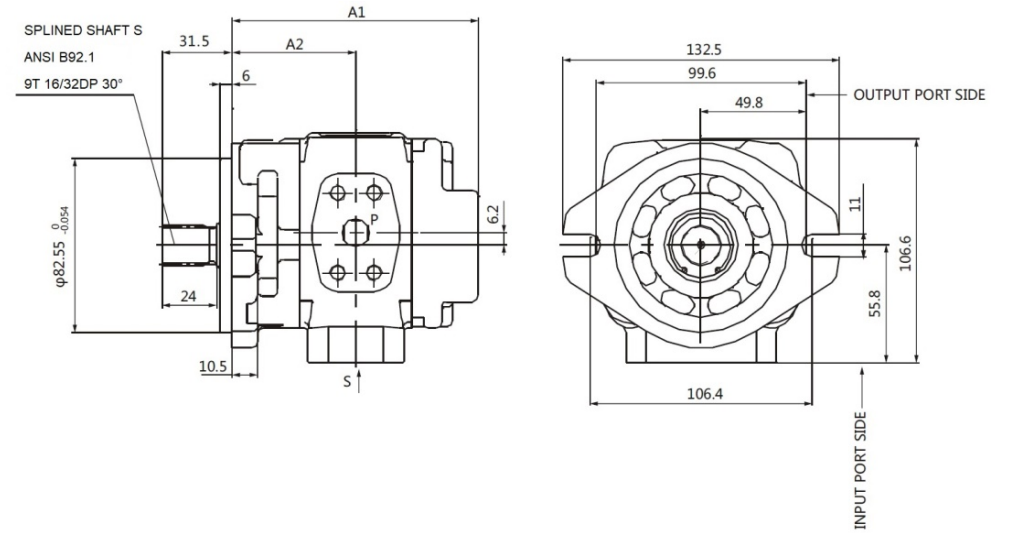

MODEL CODE	A1	A2	S	P
<b>HGO-08-01R-VSC</b>	107	54	SAE 3000 ¾ (Ø19)	SAE 3000 ½ (Ø13)
<b>HGO-10-01R-VSC</b>	111	56	SAE 3000 1 (Ø21)	
<b>HGO-13-01R-VSC</b>	117.5	59.25		
<b>HGO-16-01R-VSC</b>	123	62	SAE 3000 1¼ (Ø26)	SAE 3000 ¾ (Ø18)
<b>HGO-20-01R-VSC</b>	131	66		

Port flange dimension page 9

## INSTALLATION DIMENSIONS

HG1-※-01R-VPC (P SHAFT)

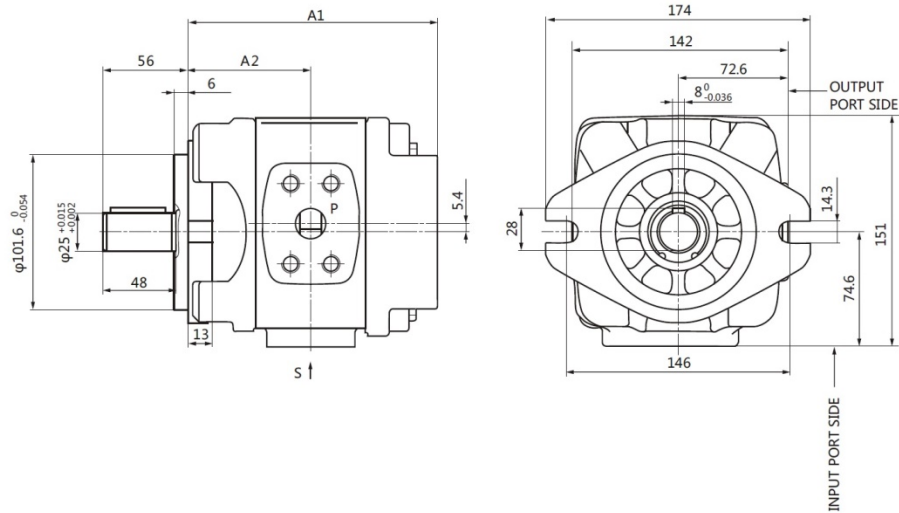

MODEL CODE	A1	A2	S	P
<b>HG1-25-01R-VPC</b>	139	73	SAE 3000 1¼ (Ø32)	SAE 3000 ¾ (Ø18)
<b>HG1-32-01R-VPC</b>	146	76.5		SAE 3000 1
<b>HG1-40-01R-VPC</b>	153	80		(Ø20)
<b>HG1-50-01R-VPC</b>	163	85		
<b>HG1-63-01R-VPC</b>	177	92		

Port flange dimension page 9

## INSTALLATION DIMENSIONS

HG1-※-01R-VSC (S SHAFT)

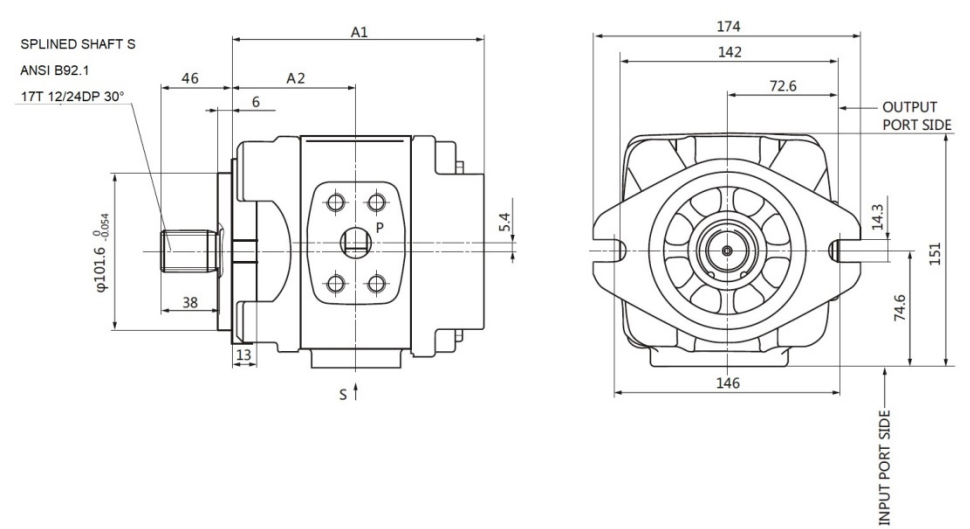

MODEL CODE	A1	A2	S	P
<b>HG1-25-01R-VSC</b>	139	73	SAE 3000 1¼ (Ø32)	SAE 3000 ¾ (Ø18)
<b>HG1-32-01R-VSC</b>	146	76.5		SAE 3000 1
<b>HG1-40-01R-VSC</b>	153	80		(Ø20)
<b>HG1-50-01R-VSC</b>	163	85		
<b>HG1-63-01R-VSC</b>	177	92		

Port flange dimension page 9

**INSTALLATION DIMENSIONS**

HG2-※-01R-VPC (P SHAFT)

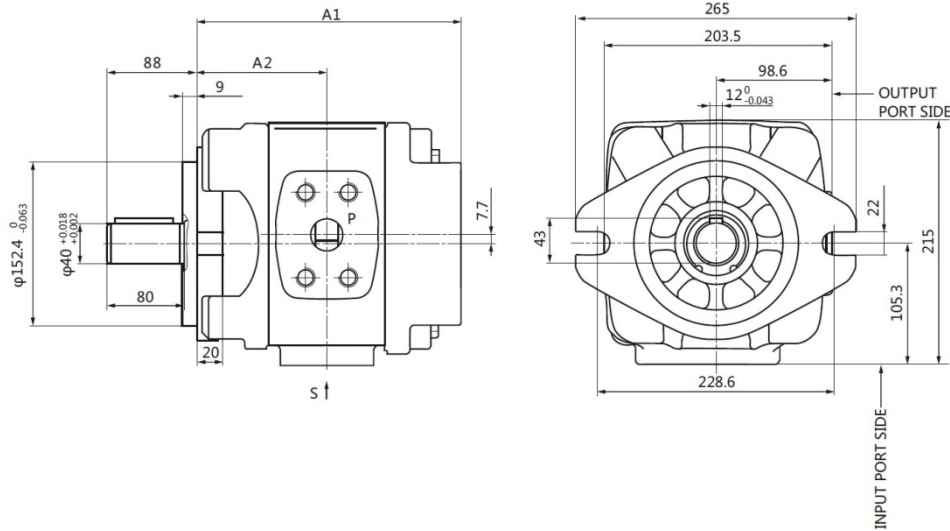

**INSTALLATION DIMENSIONS**

HG2-※-01R-VSC (S SHAFT)

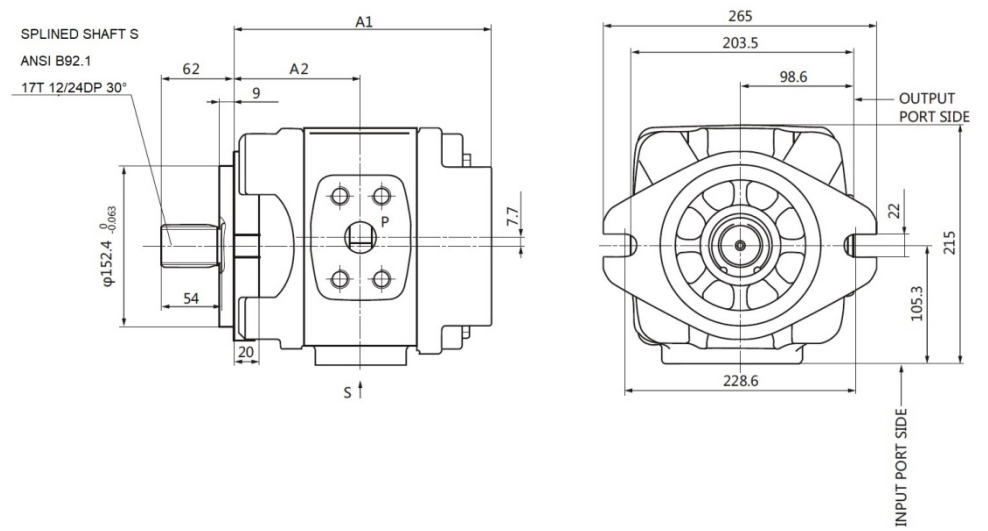

MODEL CODE	A1	A2	S	P
<b>HG2-80-01R-VPC</b>	204	109.5	SAE 3000 2 (Ø50)	SAE 3000 1½ (Ø32)
<b>HG2-100-01R-VPC</b>	213	114		
<b>HG2-125-01R-VPC</b>	225	120	SAE 3000 2½ (Ø63.5)	SAE 6000 1½ (Ø38)
<b>HG2-160-01R-VPC</b>	243	129	SAE 3000 3 (Ø76)	

MODEL CODE	A1	A2	S	P
<b>HG2-80-01R-VSC</b>	204	109.5	SAE 3000 2 (Ø50)	SAE 3000 1½ (Ø32)
<b>HG2-100-01R-VSC</b>	213	114		
<b>HG2-125-01R-VSC</b>	225	120	SAE 3000 2½ (Ø63.5)	SAE 6000 1½ (Ø38)
<b>HG2-160-01R-VSC</b>	243	129	SAE 3000 3 (Ø76)	

Port flange dimension page 9

Port flange dimension page 9

**PORT FLANGE DIMENSIONS**

INPUT PORT S

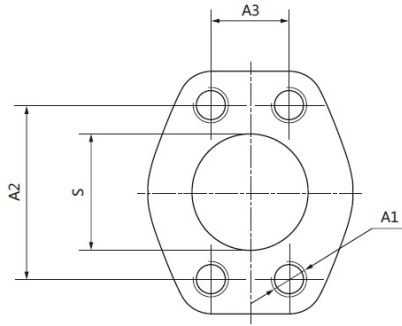

OUTPUT PORT P

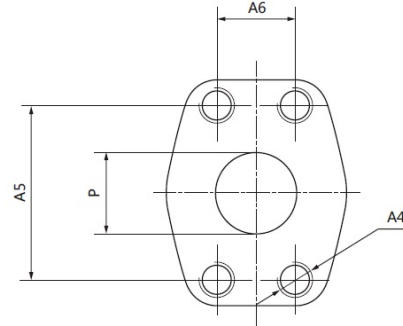

MODEL	SIZES	S	A1	A2	A3	P	A4	A5	A6
<b>HG0</b>	8	SAE 3000 ¾ (Ø19)	M10 DEEP 15	47.6	22.2	SAE 3000 ½ (Ø13)	M8 DEEP 13	38.1	17.5
	10	SAE 3000 1 (Ø21)		52.4	26.2				
	13			SAE 3000 ¾ (Ø18)	M10 DEEP 15	47.6	22.2		
	16	20						SAE 3000 1 ¼ (Ø26)	58.7
<b>HG1</b>	25	SAE 3000 1 ¼ (Ø32)	M10 DEEP 17	58.7	30.2	SAE 3000 ¾ (Ø18)	M10 DEEP 17	47.6	22.2
	32					SAE 3000 1 (Ø20)			
	40						52.4	26.2	
	50								
	63								
<b>HG2</b>	80	SAE 3000 2 (Ø50)	M12 DEEP 20	77.8	42.9	SAE 3000 1 ½ (Ø32)	M12 DEEP 20	69.9	35.7
	100								
	125	SAE 3000 2 ½ (Ø63.5)	M16 DEEP 25	88.9	50.8	SAE 6000 1 ½ (Ø38)	M16 DEEP 25	79.4	36.5
	160	SAE 3000 3 (Ø76)							