

MASSIMA PRESSIONE, DIRETTE, OTTURATORE CONICO
DIRECT, POPPET TYPE RELIEF

VSC-80

05.13.02 - X - Y - Z

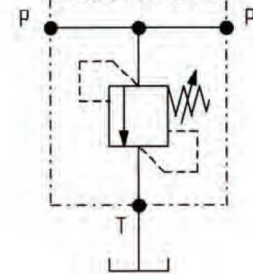
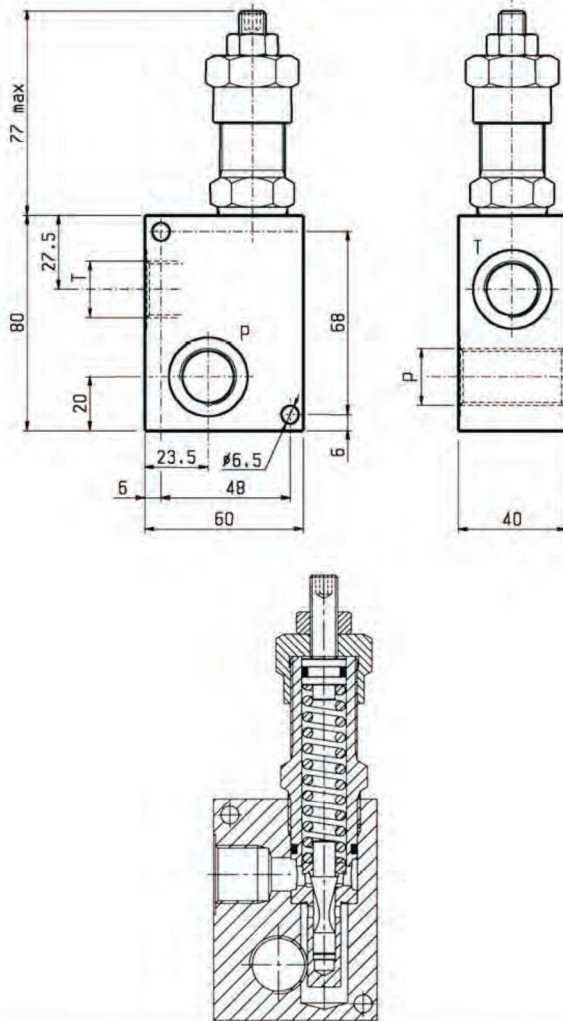

DATI TECNICI / TECHNICAL DATA

Pressione di lavoro max. 250 bar
 Max. working pressure 250 bar

Portata max. 80 l/min
 Flow max. 80 l/min

Peso 0.75 kg
 Weight 0.75 kg

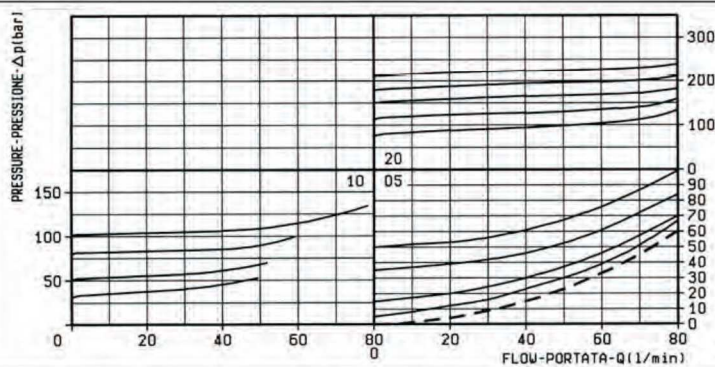

X REGOLAZIONI ADJUSTMENTS

03	vite esterna esagono incassato leakproof hex. socket screw	
04	volantino e dado handknob and locknut	
	cappello per piombatura sealing cap codice / ordering code 03.05.01.001	

MOLLE / SPRINGS

Z	Campo taratura min - max bar Adj. press. range bar	Incremento press. bar / giro vite Press. increase bar / turn	Taratura standard bar (Q = 5 l/min) Std. setting bar (Q = 5 l/min)	Cod. ordinazione Ordering code	Colore Colour
05	5-50	6	50	03.51.01.020	nero black
10	35-100	12	100	03.51.01.001	blu blue
20	80-250	27	200	03.51.01.010	rosso red

Y ATTACCHI / PORT SIZE

Y	P - T
03	G 1/2
04	G 3/4